

Instruction for use

Small Interface Cable Adapter, SICA20F2P

1. Product description

The SICA20F2P is designed to save space on the target board when using JTAG equipment to test, debug or evaluate a system. The target board connector has a 5 x 7mm footprint, which is 1/6th the size compared with traditional connector with 2.54mm pitch. This cable adapter converts 2.54mm pitch connector at an emulator side into 0.5mm pitch at a target board. Therefore, this cable can be placed closed to CPU. The target board connector surface mounted on PCB without needing any “through holes”. Now, the other side of PCB is available for mounting more components.

2. Specifications

2.1 Operating and Storage environments:

	Title	Operating environment	Storage environment
1.	Temperature	10 to 35°C	-10 to 50°C
2.	Relative humidity	35 to 80% (No condensation on any devices)	
3.	Chemical gas	No corrosive gas should exist in the environment.	

2.2 Mechanical and Electrical specifications:

	Title	Specifications
1	Outer dimensions	34 x 52 x 17mm
2	Connector at an emulator side	HIF3FC-20PA-2.54DSA(71)
3	Header at target side	Custom made connector, 20pins, 0.5 mm pitch
4	Socket at target side	Custom made connector, 20pins, 0.5mm pitch
5	Cable material	FPC, polyamides, double layers
6	DC resistance	300m Ω Max
7	Life of connectors	500 times Min
8	Current rating	0.5A/line Max

2.3 The kit includes:

- SICA20F2P cable One piece
- Mating socket at a target board(SICA2P20S) One piece
- Notes for handling SICA One piece

2.4 Recommend soldering temperature profile on the surface of the mating socket at target side, SICA2P20S.

1. Please visit the following web site to get the target board footprint pattern.
http://www.tetc.co.jp/pdf/sica_zumen/sica2p20s.pdf

2. The thickness and opening of metal mask stencils for SICA2P20S

Thickness : 150 μ
Opening of metal mask stencils : 60%

3. Soldering temperatures :

- a . Lead free soldering (Sn-3Ag-0.5Cu)

Solder reflow equipment :

Preheating temperature : 220°C for 40 seconds max.

Maximum temperature : 260°C

Hand soldering :

Maximum temperature : 380°C for 3 seconds or less.

- b. Tin-lead soldering

Solder reflow equipment :

Preheating temperature : 200°C for 30 seconds max.

Reflow temperature : 245°C

Hand soldering :

Maximum temperature : 350°C for 3 seconds or less.

3. How to use it:

1. Turn off the power to emulator and the target board! Connect the emulator cable, the emulator and target board as shown in Fig 3.1.

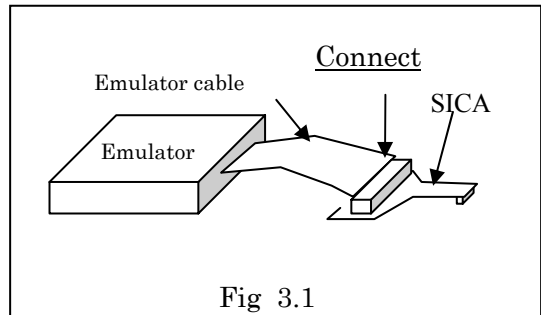

A polarity key prevents the user to plug the emulator cable and the SICA together in the wrong direction as shown in Fig 3.2. Check the key's position before assembling the header and the socket.

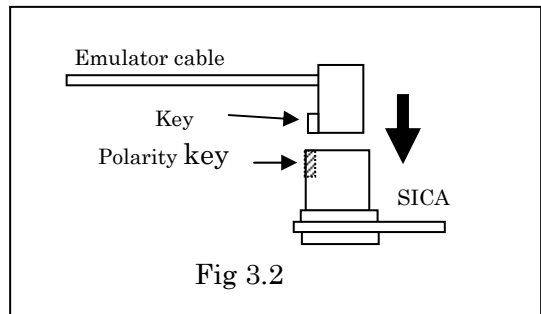

2. Again observing the proper key alignment, plug the socket on SICA cable target end onto the header on the target board as shown in Fig3.3.

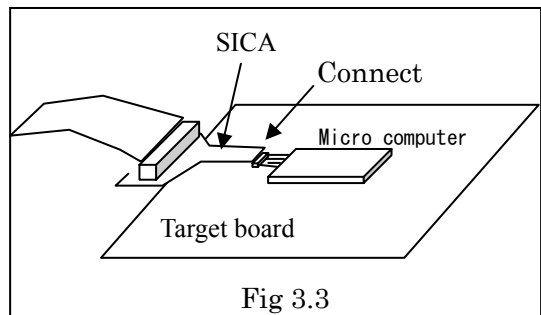

4. Cable wiring diagram

Cable wiring diagram is shown in Fig4.1. Triangle mark indicates pin#1. The pin#1 on the SICA connected to pin#1 on the other end. That is, pins are connected to straight across the cable.

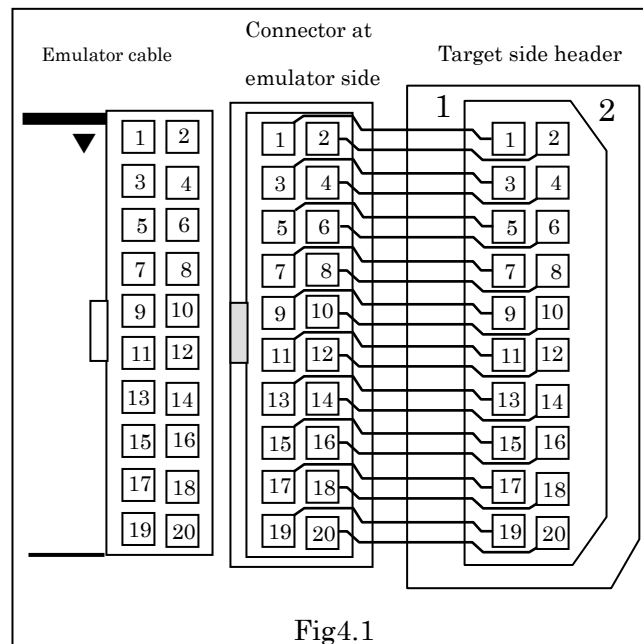

5. Notes for handling SICA -Small Interface Cable Adapter-

- 1) SICA is developed for tests, evaluations, and / or development of the electronics system development in laboratory environment; Therefore SICA does not satisfy any EMI standards or safety rules.
- 2) SICA should not be used for the electronics or electrical systems where EMI and reliability against environments can be a safety factor, such as transportation, medical, navigation, nuclear power control system and etc.
- 3) While developing a new application using SICA make sure you follow the pin diagram exactly as shown in this manual.
- 4) Do NOT bend flex cable too sharply, because it might break the internal conductive trace. Insert or extract the cable using the stiffener.

Specifications, the mechanical construction, all other information might be changed without notice.

TOKYO ELETECH CORPORATION

〒110-0006

3-10 Akihabara Taito-ku,

TOKYO JAPAN

TEL : +81-(0)3-5295-1661

FAX : +81-(0)3-5295-1775

URL : <http://www.tetc.co.jp/>

2006.06.30 TET-MANU-SICA20F2P-Rev2